



1 1/2" Angle Valve FxF with Hydrolator M4070



300 lb (2070 KPa) pressure tested approved valve. Heavy Duty 1-1/2" (38 mm) angle hose and hydrolator valve.

Automatically drains and vents, safeguarding against hose deterioration. O-ring packing and red cast handle.

Forgeline Bonnett and Seat Assembly. UL/ULC listed and FM Approved.

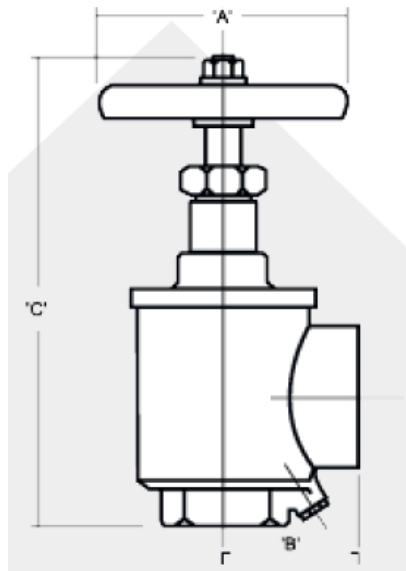

A= 4" (100mm)
B= 2 1/4" (56mm)
C= 8" (OPEN) (200mm)
C= 7" (CLOSED) ((175mm)

Weight: 4lbs 1.8Kg

Finish: Cast Brass



www.amerex-mexico.com

ventas@amerex-mexico.com

Conmutador: (81) 1534.9214